



**Savannah®**

AGRO-FORESTRY SOLUTIONS

## FEATURES

- Heavy duty Magnum™ High-lift hubs and spindles
- (4) four 36" disks
- Patented "High Lift" jump arms with high 36" total clearance
- 3 Year Spindle warranty against breakage (Does not cover thread repair)
- 2.5 gallon accumulator connected to the Stump-Jump™ hydraulic relief system
- 5" x 12" Lift Cylinder
- Model Range for 175, 200, 250 and 300 horsepower class Dozers
- Standard 1m (40") Packer or optional Chopper Roller available
- Optional 2.4m (8ft) Packer available
- Cuts a 2.3m (7.5 ft) 100% cultivated path
- DIMENSIONS:
  - Width: 2.8m (9ft 4in)
  - Length: 6m (19ft 11in)
  - Height: 1.8m (6ft 2in)
  - Weight: 4630kg (10,190lbs)
- Horsepower Requirements:
  - Skidders: 190 hp or greater
  - Dozers: 160 hp or greater





# Magnum™ 150 Full Till' Bedding Plow



*The Magnum™ 150 trailing plow provides Complete Cultivation under the planting zone by using an inner disk set to cultivate directly under the planting zone of the seedling.*

The Magnum 150 provides Full Tillage under the planting zone by using a inner disk set to cut directly under the planting zone of the seedling.

Savannah's unique Full Till' Jump Arm geometry uses a 36" inch disk as an effective means to cut through root mat and compacted soils. The Heavy Duty High Lift Magnum Jump Arm provides tillage 10-14" deep and is also available with an optional independent hydraulic accumulator for maximum penetration in extreme conditions.

The Magnum 150 High Lift Jump Arm system is patented and provides 36" of clearance under the disk when fully deflected, this prevents the disk from hanging on high stumps and improves disk, spindle and displacement cylinder life.

### FEATURES

- Produces a 7 ft wide 20" tall well tilled bed
- Inner disks tears through heavy root mat and cultivates to 12 inches deep under planting zone
- A 48" coultter and subsoil tine are available should deeper center soil fracture be desired.
- Tillage action keeps debris out of the center of the bed
- High Lift™ Jump Arm system provides 36" of clearance under the disk for years of low maintenance production
- Operates on lower horsepower tractors
- **US Pat. No. 6213220**

[www.savannahglobal.com](http://www.savannahglobal.com)

[sg@savannahglobal.com](mailto:sg@savannahglobal.com)

+1 (912) 964-2214 Outside US /1 800 240-8358 In the US

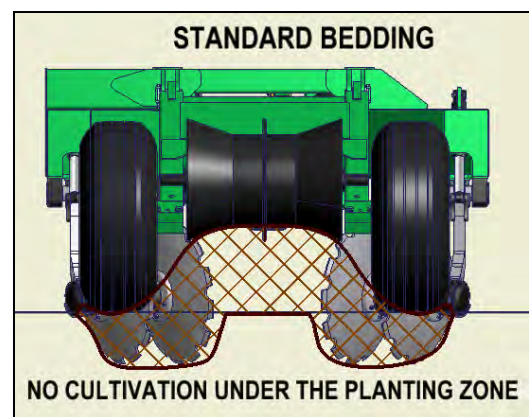
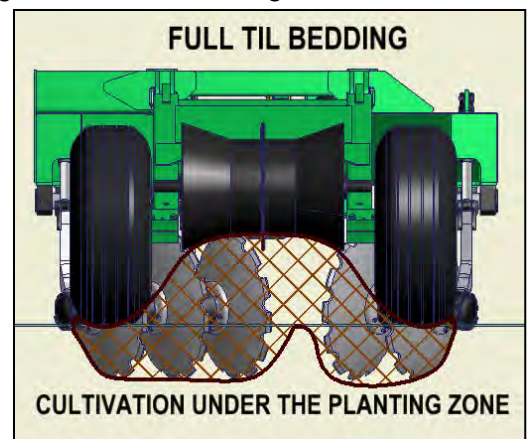

© Copyright 2005





*Complete Cultivation Under the Planting Zone*



**Specifications:**

- Heavy duty Magnum™ hubs and spindles, Warranted against breakage.
- New Patented “High Lift” jump arms with high 36” total clearance
- 2.5 gallon accumulator connected to the Stump-Jump™ hydraulic relief system
- Optional Center Jump Arm Accumulator
- Standard 40” Packer or optional Chopper Roller available
- Cuts a 7 ft. 6 in. 100% cultivated path
- Horsepower Requirements:  
 Skidders: 200 hp or greater  
 Dozers: 150 hp or greater

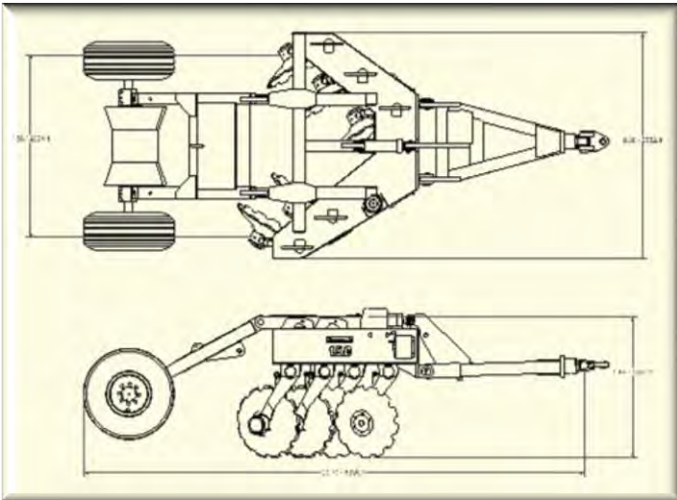

**DIMENSIONS**

Height : 5.0ft    Width: 9.36 ft  
 Length: 20ft    Cut: 7.5ft  
 Weight: 10,700 lbs

**DEALER INFORMATION**



Savannah Forestry Equipment, LLC  
 P.O. Box 8606  
 Savannah, GA 31412